

HONDA SUPER CUB C125 STREET SPORTS FULL SYSTEM GP-MAGNUM

Be sure to read the instruction carefully before starting the work. It is necessary to follow the contents to install Yoshimura product.



- CAUTION** During the work, be careful not to damage each parts.
- CAUTION** Torque specification must be followed. If neglected, it may cause bolt and nut to fell off and damage to Yoshimura exhaust system and motorcycle.
- CAUTION** Before beginning installation, let motorcycle cool down.
- CAUTION** Metal Magic sleeve is coating painted silencer sleeve. Handle with care not to be hit or scratched by surroundings as the coating may come off. When cleaning silencers, use soft cloth and do not use metal polish or parts cleaner.
- CAUTION** Titanium Blue sleeve is colored by anodizing. Handle with care as the color may change. When cleaning silencer, use soft cloth with dish soap but do not use metal polish or chemical cleaner.

1. Product Information :

| Description | HONDA SUPER CUB C125 STREET SPORTS FULL STSTEM GP-MAGNUM | Cyclone Type | H40FSC11 |
|-------------|--|-------------------------|----------------------|
| Part Number | Stainless Sleeve (SS) : 180A-40F-5U50 | Main Material | Stainless steel |
| | Satin Finish Sleeve (SSF) : 180A-40F-5U30 | Weight [STD : 3.9kg] | (SS) & (SSF) : 3.0kg |
| | Titanium Sleeve (ST) : 180A-40F-5U80 | | (ST) & (STB) : 2.8kg |
| | Titanium Blue Sleeve (STB) : 180A-40F-5U80B | | (SC) : 2.7kg |
| | Carbon Sleeve (SC) : 180A-40F-5U90 | | |

2. Applicable Model :

| | |
|-------|----------------------|
| Model | HONDA SUPER CUB C125 |
|-------|----------------------|

3. Contents:

| No. | Descriptions | Part No. | Q'ty | No. | Descriptions | Part No. | Q'ty |
|-----|------------------------------------|---------------|------|-----|-------------------------------|--------------|------|
| 1 | Exhaust Pipe | 111-40F-5U00 | 1 | 8 | Washer M6 (SUS) 6-13-1.0 | 812-206-1310 | 2 |
| 2 | Silencer Assy Stainless Sleeve | 186-40F-5U50 | 1 | 9 | Washer M8x20 Cr3 | 812-108-2000 | 3 |
| | Silencer Assy Satin Finish Sleeve | 186-40F-5U30 | | 10 | Washer M8x26 Cr3 | 812-108-2600 | 2 |
| | Silencer Assy Titanium Sleeve | 186-400-5U80 | | 11 | Flange Nut M6 P1.0 (FE) 3CR | 823-006-1000 | 2 |
| | Silencer Assy Titanium Blue Sleeve | 186-400-5U80B | | 12 | Flange Nut M8 P1.25 (FE) 3CR | 823-008-1250 | 1 |
| | Silencer Assy Carbon Sleeve | 186-400-5U90 | | 13 | Grommet Rubber | 553-565-0000 | 1 |
| 3 | Silencer Bracket#1 | 161-40F-0300 | 1 | 14 | Grommet Spacer (8-12-12) | 850-208-1212 | 1 |
| 4 | Silencer Bracket#2 | 161-40F-0310 | 1 | 15 | Exhaust Spring (Floating) MID | 118-001-2000 | 2 |
| 5 | Cap Bolt M8x20 (SUS) | 800-208-5020 | 2 | ※ | Spring Puller Tool | 100-000-0000 | 1 |
| 6 | Button Bolt M6x20 (SUS) | 803-206-4020 | 2 | | | | |
| 7 | Button Bolt M8x30 (SUS) | 803-208-5030 | 1 | | | | |

Parts Diagram

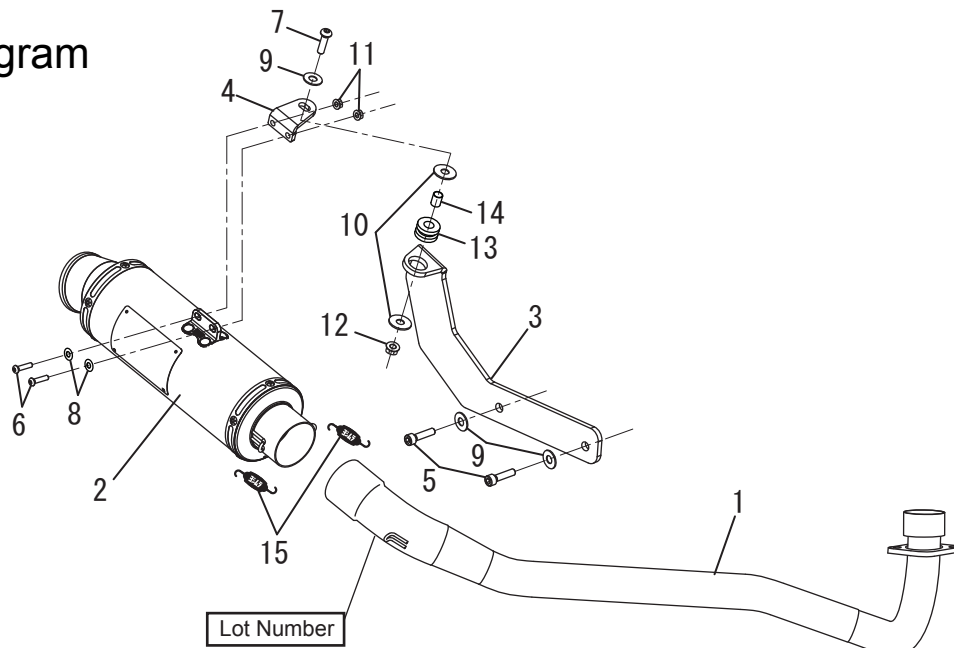

4. INSTALLATION STEPS :

- 1) Check that all the component parts are in hand.
- 2) According to Honda Service Manual, remove Footrest. Then, remove stock exhaust system (See Fig. 1).

CAUTION When removing exhaust system, be careful not to damage frame, swing arm or other components.

REFERENCE stock nuts removed at this stage are reused when mounting Exhaust Pipe.

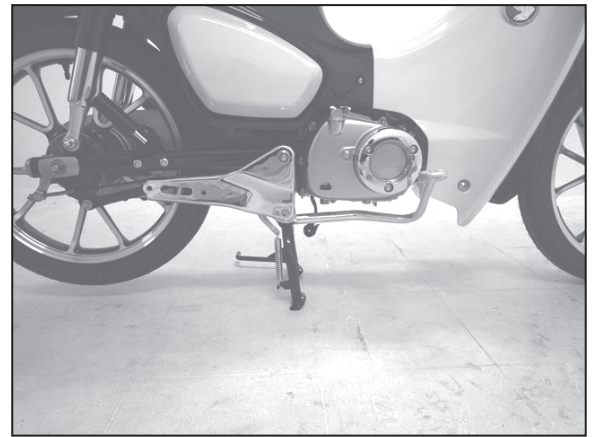

FIG. 1

- 3) Mount Grommet Rubber and Grommet Spacer on Silencer Bracket#1 (See Fig. 2). Using Cap Bolt M8x20 (SUS), Washer M8x20 and Stock nuts mount Silencer Bracket on the Vehicle silencer mounting position (See Fig. 2, 3).

Tightening Torque Cap Bolt M8x20 : 23 Nm

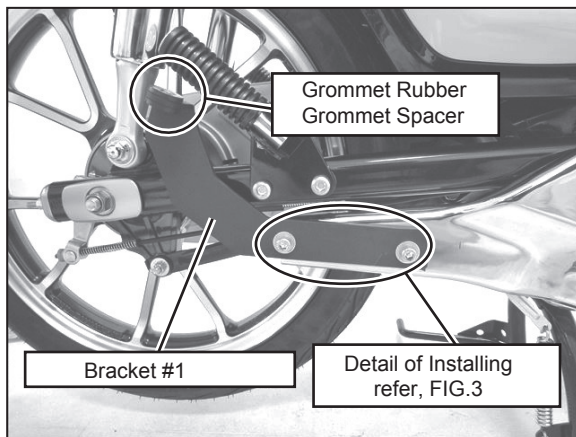

FIG. 2

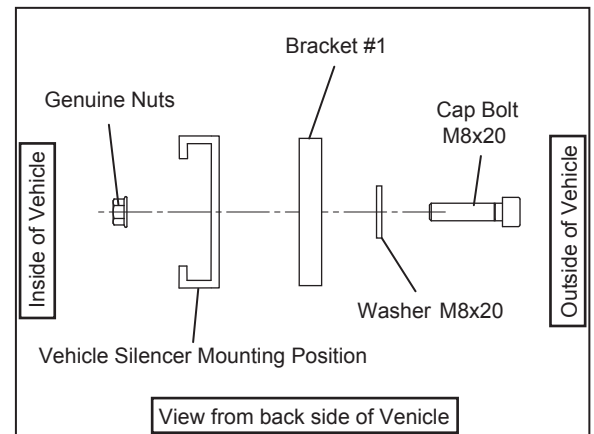

FIG. 3

- 4) Mount Silencer Bracket #2 on Silencer Assy with 2 of each Button Bolt M6x20, Washer M6x13 and Flange Nut M6 (See Fig. 4). Tighten bolts by hand only at this stage.

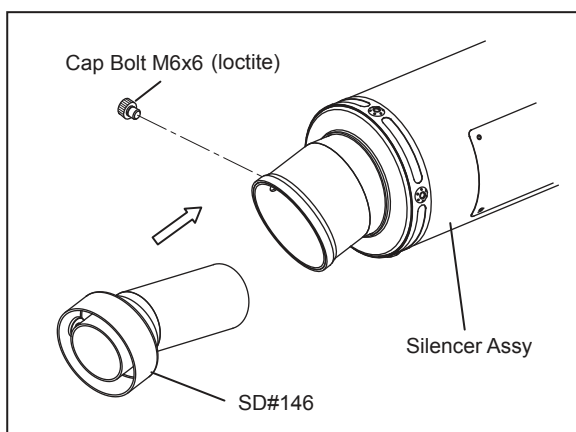

FIG. 5

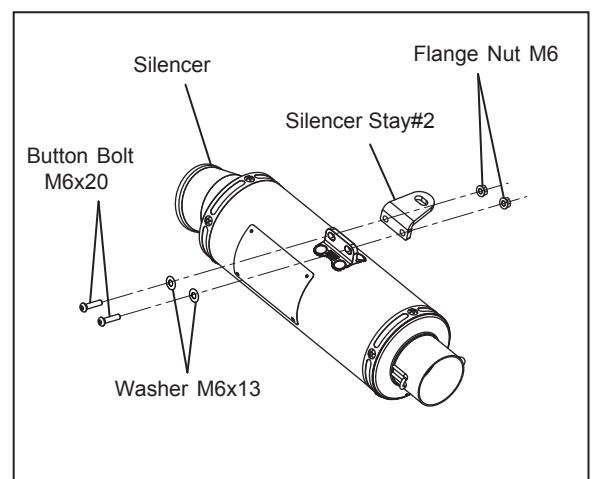

FIG. 4

- 5) Install SD#146 with Cap Bolt M6x6 if necessary (See Fig. 5).

REFERENCE

Without dB killer : 96 dB/3,750rpm

With dB killer SD#146 : 89 dB/3,750rpm

Tightening Torque Button Bolt M6x6 : 10Nm

CAUTION Please apply loctite with Cap Bolt M6x6

CAUTION Torque specification must be followed.

6) Make sure to insert HONDA genuine exhaust gasket into exhaust port. Then, mount Exhaust Pipe on exhaust port with 2 stock nuts Tighten nuts by hand only at this stage (See Fig. 6 & 7).

CAUTION Use new HONDA genuine exhaust gasket

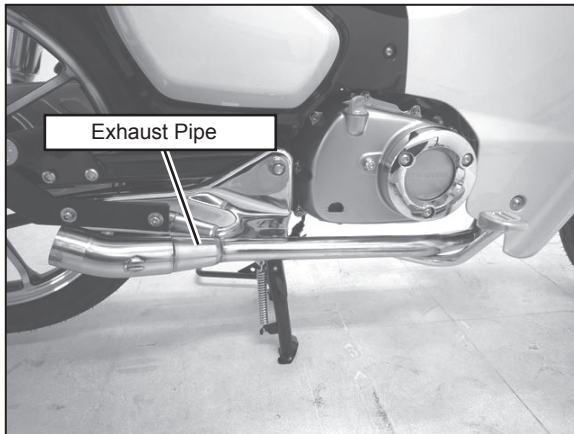

FIG. 6

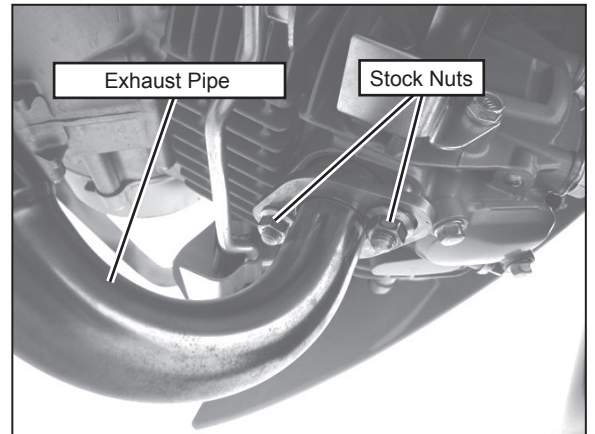

FIG. 7

7) Install Exhaust Spring onto each spring hook on Exhaust Pipe and Silencer Assy (See Fig. 8).

CAUTION Make sure that exhaust spring is hooked to spring installation tool firmly. If neglected, it may cause injury

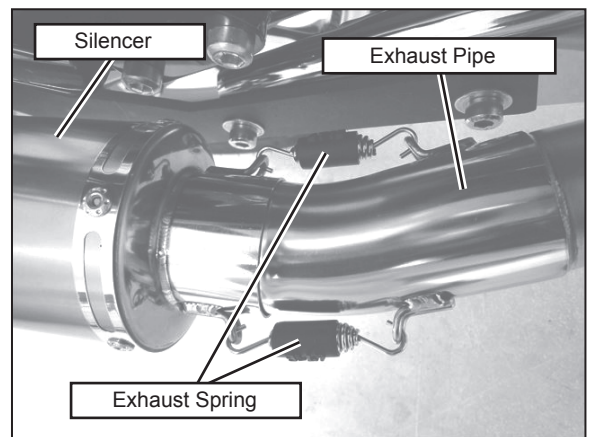

FIG. 8

8) Mount Silencer Bracket #1 on Silencer Bracket #2. Using Button Bolt M8x30 (SUS), Washer M8x20, 2-Washer M8x26 (See Fig. 9, 10). Tighten nuts by hand only at this stage

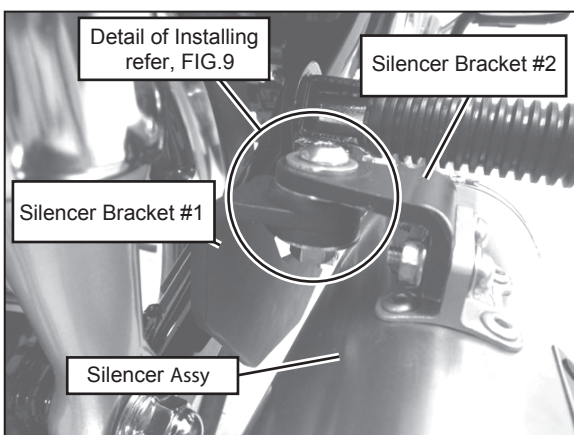

FIG. 9

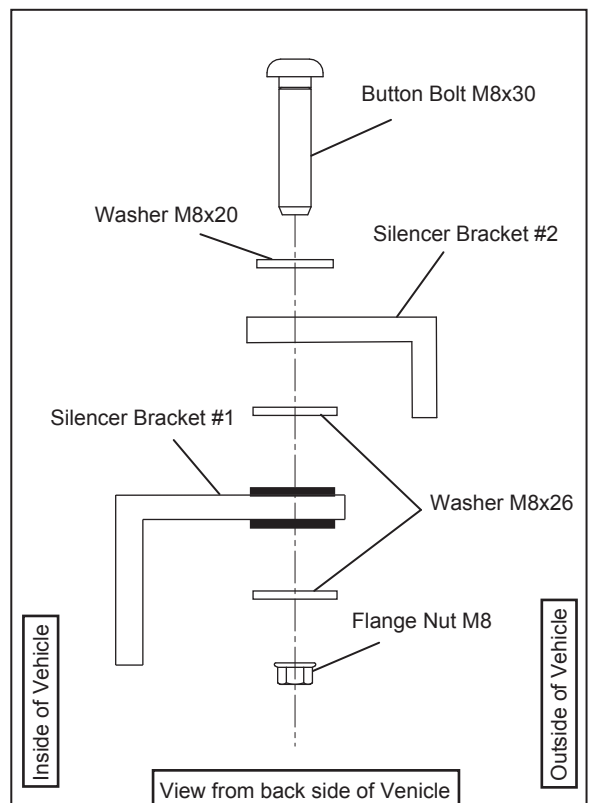

FIG. 10

- 9) Re-mount Footrest
- 10) Check from back and adjust angle of Silencer Assy and keep proper clearance between Yoshimura exhaust system and other components such as swing arm or brake pedal. Then, tighten and torque Exhaust Port Nuts, Button Bolt M6x20 on Silencer Bracket and Button Bolt M8x30

| | | |
|-------------------|-------------------|---------|
| Tightening Torque | Exhaust Port bolt | : 15 Nm |
| | Button Bolt M8x30 | : 23 Nm |
| | Button Bolt M6x20 | : 10 Nm |

 **CAUTION** Torque specification must be followed.

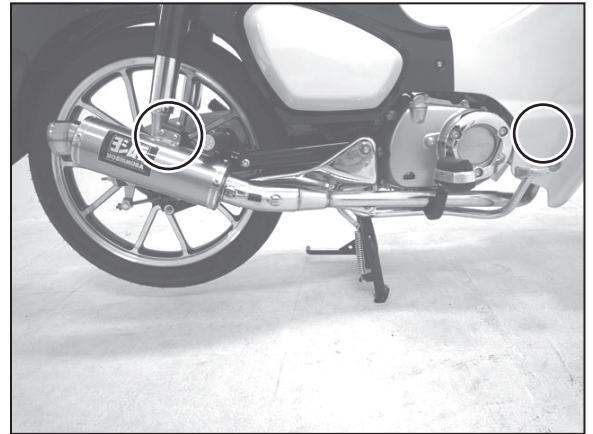

FIG. 11

- 11) Make sure to keep enough clearance between Yoshimura Exhaust System and other components such as swing arm or Silencer Bracket. In case there is no clearance, loosen bolts and readjust the position of Exhaust Pipe and Silencer Assy.
- 12) It is recommended whole Exhaust System to be wiped down with dish soap to remove oil and fingerprints. This will prevent from tarnishing of finish after Exhaust system has heated up.
- 13) Warm-up engine, and inspect the exhaust leaking. If "after fire" sounds severely, seal the gaps of joint with silicone gasket etc. Then, tighten all bolts further after engine has cooled down. If any problem is found, please follow through instruction steps carefully again.

 **CAUTION**

When cleaning silencer, use soft cloth and do not use metal polish or parts cleaner. If neglect, the paint of Emblem and Metal Magic finish may come off or Titanium Blue color may tarnish.

REFERENCE It is normal for new silencer to smoke until inside oil residue burns off.



REFERENCE

Yoshimura Asia recommends silencer inner wool repacking every 5,000km (3,000miles) in order to get Yoshimura exhaust performance fully. Climate, riding condition, and frequency of ride are direct contributing factors for inner wool worn out. Keeping high engine revolution also promotes further wool consumption. Weigh new silencer assy (or silencer assy after repacking) and record the weight in order to compare with weight after use. For silencer repacking, please contact local Yoshimura Asia distributor for further information.

- Check each bolt sometimes to see that there is no failure condition such as poor tightening.
- Quality control is implemented on all products. If, however, any defect or failure is found, please notify Yoshimura Asia through the selling dealer. Necessary technical service or replacing of the product will be made.
- Due to improvement, the specifications and price of the product are subject to change without notice.
- For any information regarding this product, please address inquiries to Yoshimura Asia Co., Ltd.

Yoshimura Asia Co., Ltd.
118/3 Moo 18, KLONGNUENG, KLONGLUANG, PATHUMTHANI 12120, THAILAND
Web site: <http://www.yoshimura.asia>