

## YAMAHA AEROX 155 STREET SPORTS FULL SYSTEM R-77S

Be sure to read the instruction carefully before starting the work. It is necessary to follow the contents to install Yoshimura product.

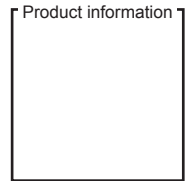

- CAUTION** During the work, be careful not to damage each parts. Torque specification must be followed. If neglected, it may cause bolt and nut to fell off and damage to Yoshimura exhaust system and motorcycle.
- CAUTION** Before beginning installation, let motorcycle cool down.
- CAUTION** Metal Magic sleeve is coating painted silencer sleeve. Handle with care not to be hit or scratched by surroundings as the coating may come off. When cleaning silencers, use soft cloth and do not use metal polish or parts cleaner.
- CAUTION** Titanium Blue sleeve is colored by anodizing. Handle with care as the color may change. When cleaning silencer, use soft cloth with dish soap but do not use metal polish or chemical cleaner.

### 1. Product Information :

Description	YAMAHA AEROX 155 STREET SPORTS FULL SYSTEM R-77S	Cyclone Type	Y314SCI11
Part Number	Stainless Sleeve (SSC) : 180A-314-5150	Main Material	Stainless Steel
	Satin Finish Sleeve (SFC) : 180A-314-5130	Weight [STD : 4.6kg]	(SSC) & (SFC) : 2.8kg
	Metal Magic Sleeve (SMC) : 180A-314-5120		(SMC) : 2.8kg
	Titanium Sleeve (STC) : 180A-314-5180		(STC) & (STBC) : 2.6kg
	Titanium Blue Sleeve (STBC) : 180A-314-5180B		

### 2. Applicable Model :

Model	YAMAHA AEROX 155
-------	------------------

No.	Descriptions	Part No.	Q'ty	No.	Descriptions	Part No.	Q'ty
1	Exhaust Pipe	181-314-5U00	1	7	Silencer Band	162-22R-G500	1
2	Silencer Assy Stainless Sleeve	186-314-5150	1	8	Silencer Band Rubber	896-016-0835	1
	Silencer Assy Satin Finish Sleeve	186-314-5130		9	Button Bolt M6x15	803-206-4015	2
	Silencer Assy Metal Magic Sleeve	186-314-5120		10	Washer M6x13	812-206-1310	2
	Silencer Assy Titanium Sleeve	186-314-5180		11	Silencer Bracket	161-314-0310	1
	Silencer Assy Titanium Blue Sleeve	186-314-5180B		12	Flange Nut M6	823-006-1000	2
3	Button Bolt M8x20	803-208-5020	1	13	Stepped Spacer 10-26-9	850-210-26A1	2
4	Washer M8x20	812-108-2000	2	14	Grommet Rubber	553-565-0000	1
5	Exhaust Pipe Bracket #2	161-314-0300	1	15	Exhaust Spring Floating (Mid)	118-001-2000	2
6	Flange Nut M8	823-008-1250	1	※	Spring Puller Tool	100-000-0000	1

### Parts Diagram

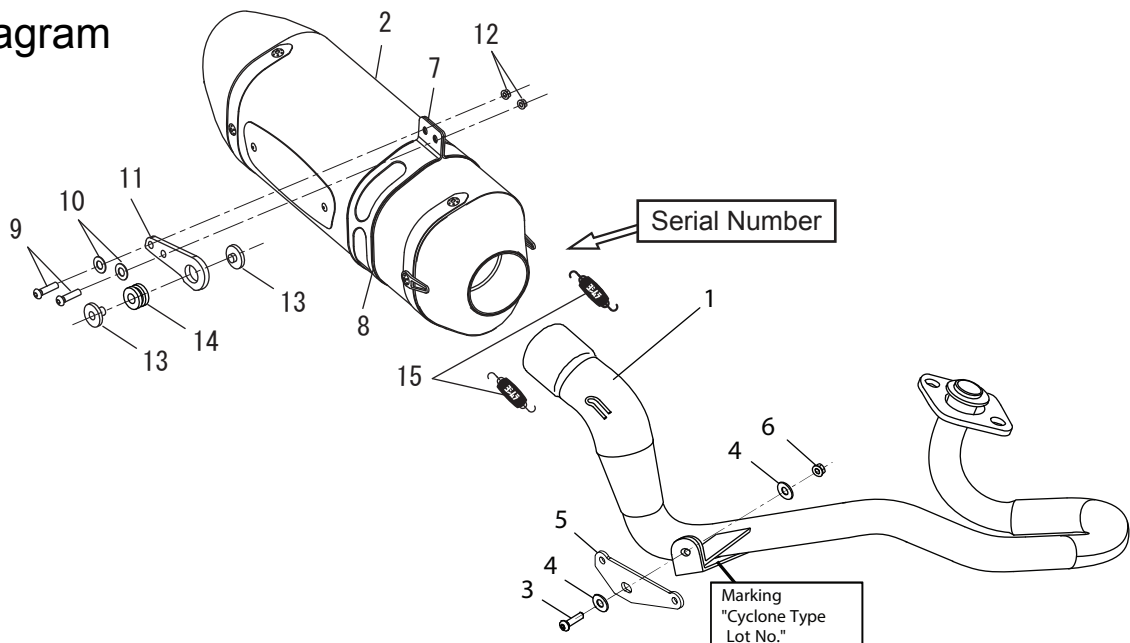

### 3. INSTALLATION STEPS :

- 1) Check that all the component parts are in hand.
- 2) According to Yamaha Service Manual, remove stock exhaust system and Radiator guard (See Fig. 1).

**CAUTION** When removing exhaust system, be careful not to damage frame, swing arm and other components.

**REFERENCE** Stock Bolts & Nuts removed at this stage are reused when mounting Yoshimura Exhaust System



FIG. 1

- 3) Remove the two bolts at the bottom of radiator (see Fig. 2)

**REFERENCE** Stock bolts removed at this stage are reused when mounting Exhaust Pipe Bracket #2

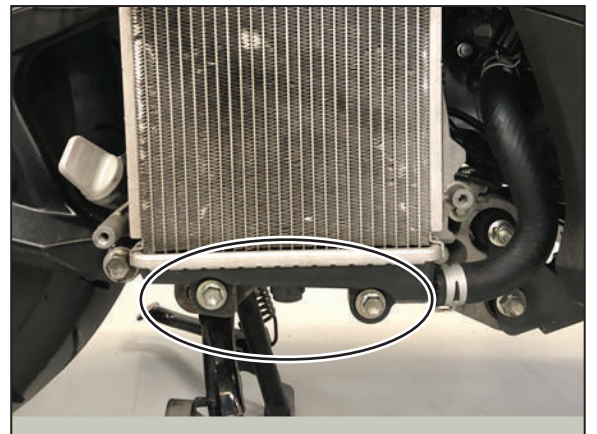

FIG. 2

- 4) Use the 2 stock bolts to mounting Exhaust Pipe Bracket #2. Tighten bolts by hand at this stage (see Fig. 3,4)

**CAUTION** Please be careful mounting Exhaust Pipe Bracket#2. The bracket position is between Radiator and Engine Stay (See Fig. 3,4)

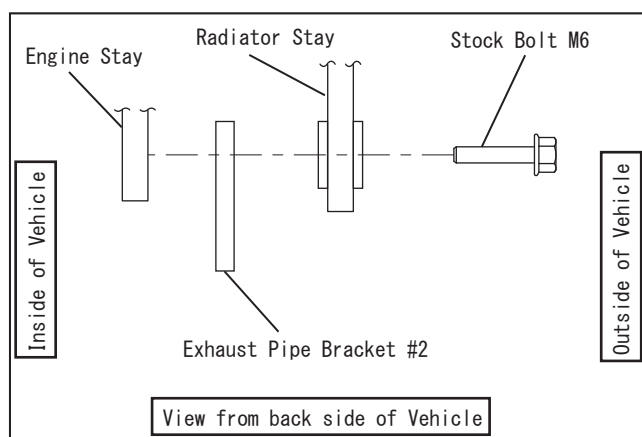

FIG. 3

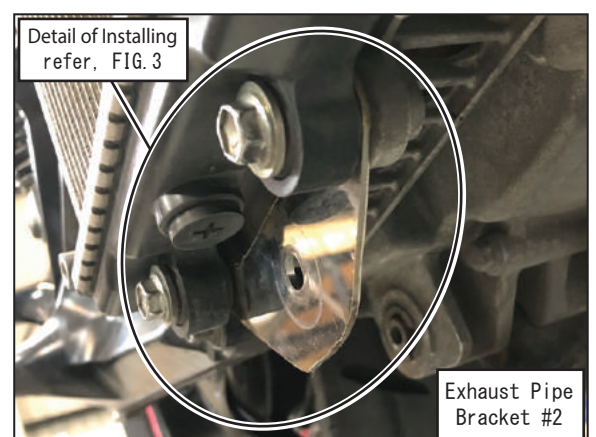

FIG. 4

- 5) Make sure to insert YAMAHA genuine exhaust gasket into exhaust port. Then, mount Exhaust Pipe on exhaust port with stock nuts. Tighten nuts by hand at this stage (See Fig. 5 & 6).

**CAUTION** Use new YAMAHA genuine exhaust gasket



FIG. 5

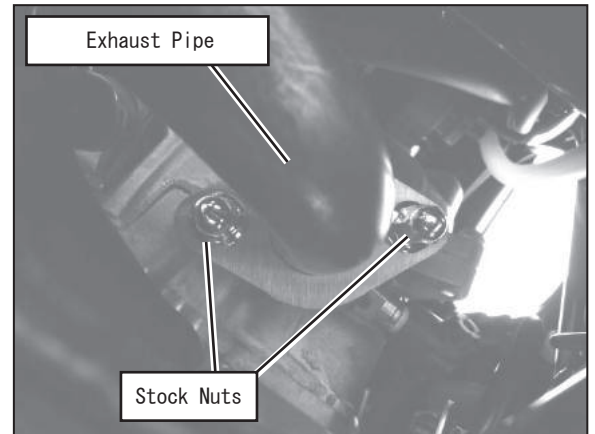

FIG. 6

- 6) Mount Exhaust Pipe Bracket #1 onto Exhaust Pipe Bracket #2 with Button Bolt M8 x 20, 2-Washer M8 x 20 and Flange Nut M8 Tighten bolt by hand only at this stage (See Fig 7, 8).

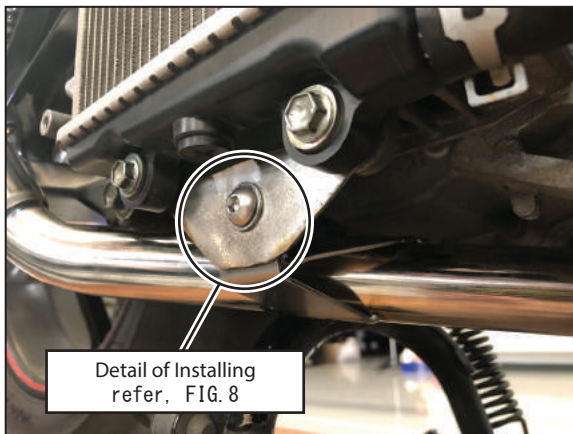

FIG. 7

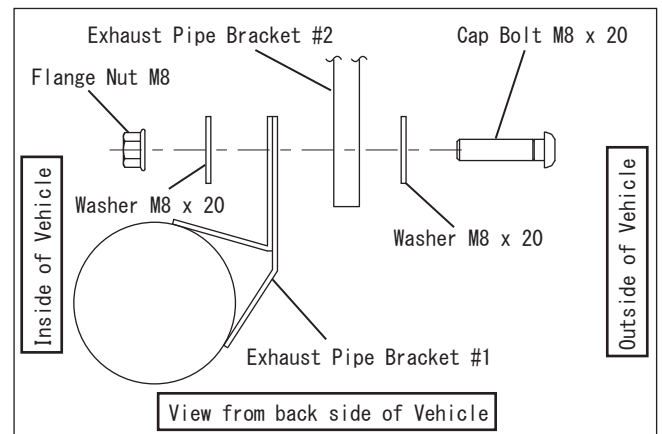

FIG. 8

- 7) Mount Grommet Rubber on Silencer Bracket (See Fig. 9).



FIG. 9

- 8) Mount Silencer Assy on the Exhaust Pipe. Then, Install Exhaust Spring onto spring hook on Exhaust Pipe and Silencer Assy (See Fig. 10).

**CAUTION** Make sure that exhaust spring is hooked to spring installation tool firmly. If neglected, it may cause injury

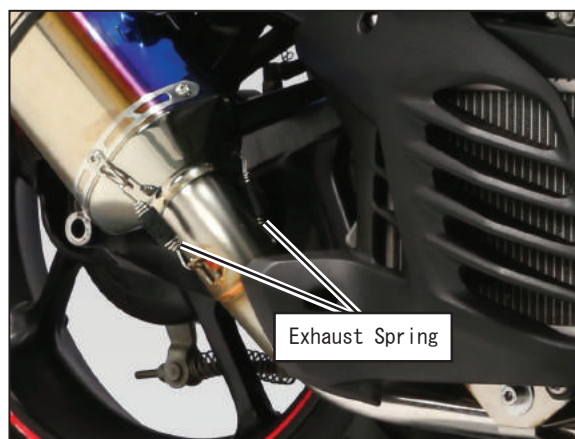

FIG. 10

- 9) Place Silencer Band Rubber inside Silencer Band, and slide them on Silencer Assy. Then, fix Silencer Band on Silencer Bracket with 2 of each Button Bolt M6x15, SUS Washer M6 and Flange Nut M6. (See Fig. 11). Tighten bolts by hand only at this stage.

**CAUTION** Be sure to place Silencer Band at right angles to Silencer Assy. If neglected, it may cause breakage to Silencer Band.

**CAUTION** Before hand-tighten Silencer Band, make sure silencer sleeve and Silencer Band fit evenly and there is no opening between them. If neglected, it may cause deformation of silencer sleeve.

**REFERENCE** Make sure not to thghten bolts completely in order to adjust the position of Silencer Band later.

**REFERENCE** Cut excess of Silencer Band Rubber with scissors etc. when placing it inside Silencer Band.

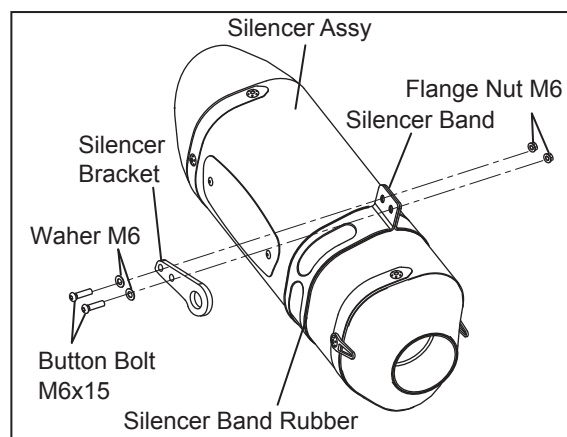
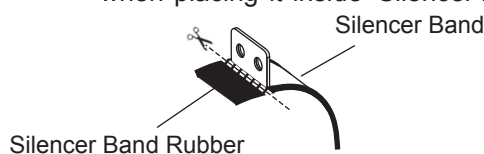

FIG. 11

- 10) Mount Silencer Bracket on Stock Silencer Bracket by Using Stock Bolt M10 and 2-Stepped Spacer 10-26-9. Tighten bolt by hand only at this stage (See Fig. 12, 13).

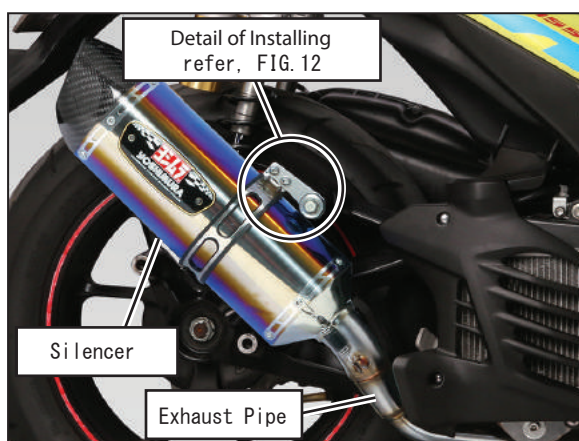

FIG. 12

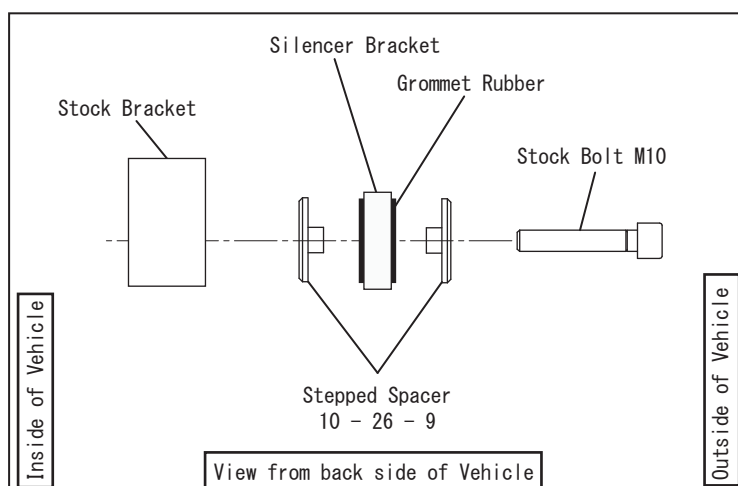

FIG. 13

- 11) Check from back and adjust angle of Silencer Assy and Keep proper clearance between Yoshimura exhaust system and Other components such as swing arm. Then, tight and torque 2-Stock Nuts of the Exhaust port, 2-Stock Bolt M6 on Exhaust Pipe Bracket #2 at bottom of radiator, Cap Bolt M8 on Exhaust Pipe Bracket #2, 2-Button bolt M6 on Silencer Bracket and Then Stock bolt M10 on Silencer Bracket (See Fig.14).



FIG. 14

Tightening Torque		
	Stock Nuts	: 15 Nm
	Stock Bolts M6	: 10 Nm
	Cap Bolts M8	: 23 Nm
	Button Bolts M6	: 10 Nm
	Cap Bolts M10	: 28 Nm

- 12) Please return the Radiator guard that remove in step 2 to the Vehicle
- 13) Make sure to keep enough clearance between Yoshimura Exhaust System and other components such as swing arm or Silencer Bracket. In case there is no clearance, Please loosen bolts and readjust the position of the Exhaust Pipe and Silencer Assy .
- 14) It is recommended that whole Yoshimura Exhaust System to be wiped down with dish soap to remove oil and fingerprints. This will prevent from tarnishing of finish after Exhaust System has heated up.

**! CAUTION** When cleaning silencer, use soft cloth and do not use metal polish or parts cleaner. If neglect, the paint of Emblem and Metal Magic finish may come off or Titanium Blue color may tarnish.

- 15) Warm-up engine, and inspect the exhaust leaking. If "after fire" sounds severely, seal the gaps of joint with silicone gasket etc. Then, tighten all bolts further after engine has cooled down. If any problem is found, please follow through instruction steps carefully again.

**REFERENCE** It is normal for new silencer to smoke until inside oil residue burns off.



**REFERENCE**

Yoshimura Asia recommends silencer inner wool repacking every 5,000km (3,000miles) in order to get Yoshimura exhaust performance fully. Climate, riding condition, and frequency of ride are direct contributing factors for inner wool worn out. Keeping high engine revolution also promotes further wool consumption. Weigh new silencer assy (or silencer assy after repacking) and record the weight in order to compare with weight after use. For silencer repacking, please contact local Yoshimura Asia distributor for further information.

- ⊙ Check each bolt sometimes to see that there is no failure condition such as poor tightening.
- ⊙ Quality control is implemented on all products. If, however, any defect or failure is found, please notify Yoshimura Asia through the selling dealer. Necessary technical service or replacing of the product will be made.
- ⊙ Due to improvement, the specifications and price of the product are subject to change without notice.
- ⊙ For any information regarding this product, please address inquiries to Yoshimura Asia Co., Ltd.

Yoshimura Asia Co., Ltd.  
118/3 Moo 18, KLONGNUENG, KLONGLUANG, PATHUMTHANI 12120, THAILAND  
Web site: <http://www.yoshimura.asia>