

HONDA ADV150 (19) STREET SPORTS FULL SYSTEM R-77S

Be sure to read the instruction carefully before starting the work. It is necessary to follow the contents to install Yoshimura product.

Product information



- CAUTION** During the work, be careful not to damage each parts. Torque specification must be followed. If neglected, it may cause bolt and nut to fell off and damage to Yoshimura exhaust system and motorcycle.
- CAUTION** Before beginning installation, let motorcycle cool down.
- CAUTION** Metal Magic sleeve is coating painted silencer sleeve. Handle with care not to be hit or scratched by surroundings as the coating may come off. When cleaning silencers, use soft cloth and do not use metal polish or parts cleaner.
- CAUTION** Titanium Blue sleeve is colored by anodizing. Handle with care as the color may change. When cleaning silencer, use soft cloth with dish soap but do not use metal polish or chemical cleaner.

1. Product Information :

Description	HONDA ADV150 (19) STREETS SPORTS R-77S	Cyclone Type	H43CSCI11
Part Number	Stainless Sleeve (SSC) : 180A-43C-5150	Main Material	Stainless Steel
	Satin Finish Sleeve (SFC) : 180A-43C-5130	Weight [STD : 5.3kg]	(SSC) & (SFC) : 2.9kg
	Metal Magic Sleeve (SMC) : 180A-43C-5120		(SMC) : 2.9kg
	Titanium Sleeve (STCC) : 180A-43C-5180		(STC) & (STBC) : 2.7kg
	Titanium Blue Sleeve (STB) : 180A-43C-5180B		

2. Applicable Model :

Model	HONDA ADV150 (19)
-------	-------------------

No.	Descriptions	Part No.	Q'ty	No.	Descriptions	Part No.	Q'ty
1	Exhaust Pipe	181-43C-5U00	1	10	Silencer Band	162-40R-G500	1
2	Silencer Assy Stainless Sleeve	186-43C-5150	1	11	Silencer Band Rubber	896-016-0835	1
	Silencer Assy Satin Finish Sleeve	186-43C-5130		12	Button Bolt M6x15	803-206-4015	2
	Silencer Assy Metal Magic Sleeve	186-43C-5120		13	Washer M6x13	812-206-1310	2
	Silencer Assy Titanium Sleeve	186-43C-5180		14	Silencer Bracket	161-43C-0020	1
	Silencer Assy Titanium Blue Sleeve	186-43C-5180B		15	Flange Nut M6	823-006-1000	2
3	Cap Bolt M8x20	800-208-5020	1	16	Cap Bolt M10x55	800-210-5055	1
4	Washer M8x20	812-108-2000	1	17	Stepped Spacer 10-26-9	850-210-26A1	2
5	Exhaust Pipe Bracket #1	161-43C-0000	1	18	Grommet Rubber	553-565-0000	1
6	Flange Nut M8	823-008-1250	1	19	Washer M10x26	812-210-2615	1
7	Cap Bolt M10x35	800-210-5035	1	20	Exhaust Spring Floating (Mid)	118-001-2000	2
8	Washer M10x22	812-210-2215	1	21*	Spacer 10-24-5	850-010-2405	1
9	Button Bolt M10x45	800-210-5045	1	※	Spring Puller Tool	100-000-0000	1

Parts Diagram

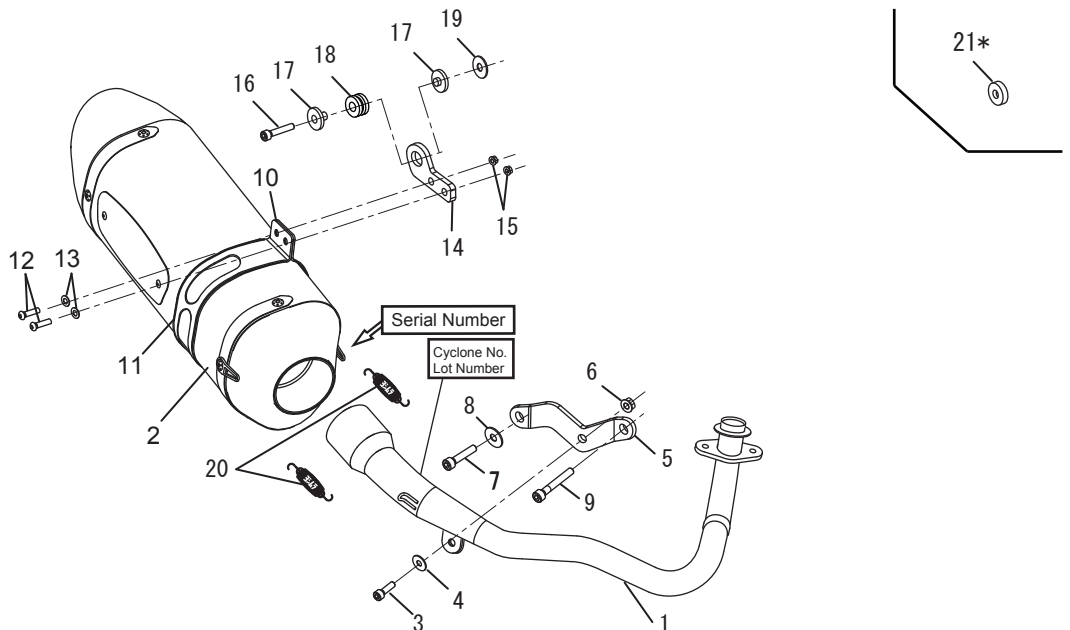

3. INSTALLATION STEPS :

- 1) Check that all the component parts are in hand.
- 2) According to Honda Service Manual, remove stock exhaust system (See Fig. 1).

CAUTION When removing exhaust system, be careful not to damage frame, swing arm and other components.

REFERENCE Stock Bolts & Nuts removed at this stage are reused when mounting Yoshimura Exhaust System

- 3) Remove the bolt and washer at swing arm (See Fig. 2).

REFERENCE Washer removed at this stage is reused when mounting Exhaust Pipe Bracket #1

- 4) Mounting Exhaust Pipe Bracket #1 by using Cap Bolt M10x45P1.25, Stock Washer, Cap Bolts M10x35P1.25 and Washer M10x22 (See Fig. 3).

Tightening Torque

Cap Bolt M10x45	: 39 Nm
Cap Bolt M10x35	: 39 Nm

CAUTION Torque specification must be followed.

- 5) Mounting Grommet Rubber and Stepped Spacer 10-26-9 on Silencer Bracket (See Fig.4).



FIG. 1

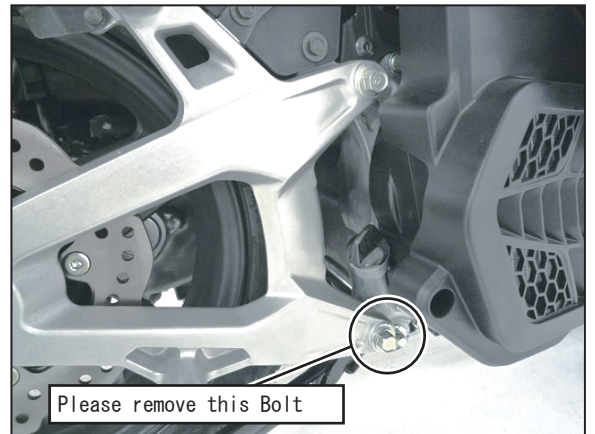

FIG. 2

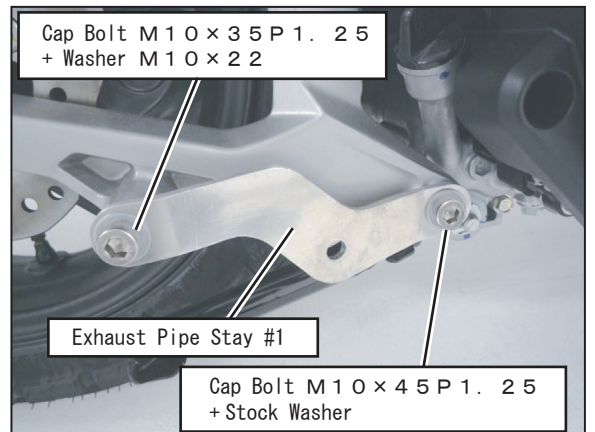

FIG. 3

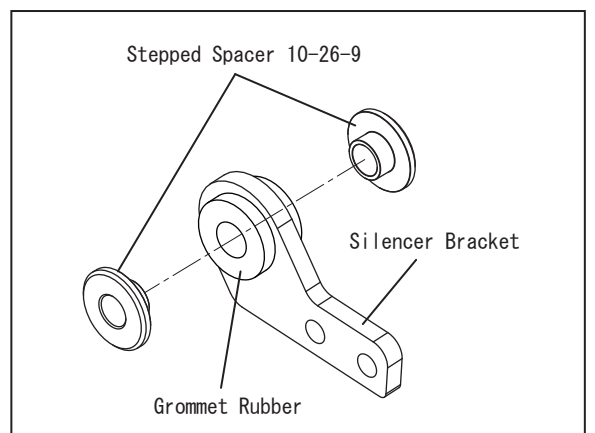

FIG. 4

- 6) Make sure to insert HONDA genuine exhaust gasket into exhaust port. Then, mount Exhaust Pipe on exhaust port with stock nuts. Tighten nuts by hand at this stage (See Fig. 5 & 6).

CAUTION Use new HONDA genuine exhaust gasket

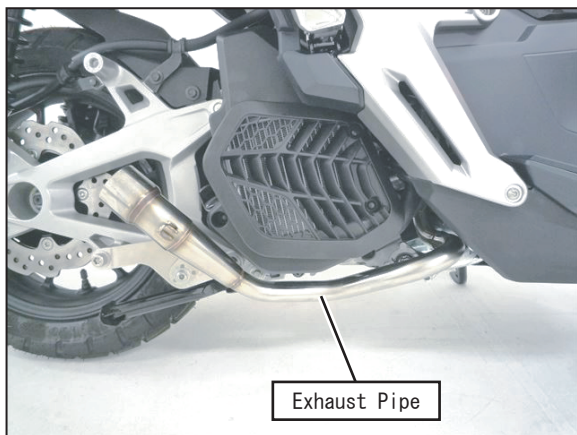

FIG. 5

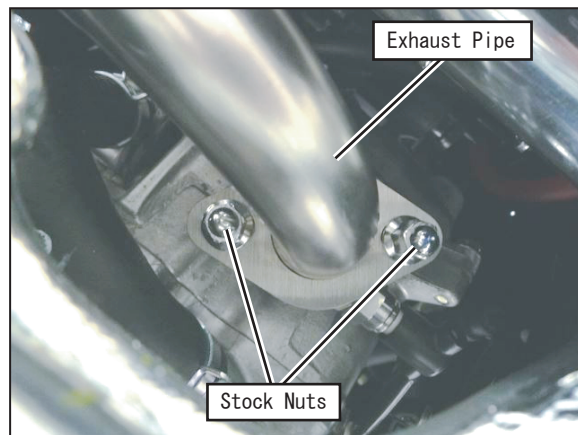

FIG. 6

- 7) Mount Exhaust Pipe onto Exhaust Pipe Bracket #1 with Cap Bolt M8 x 20, Washer M8 x 20 and Flange Nut M8. Tighten bolt by hand only at this stage (See Fig 7, 8).

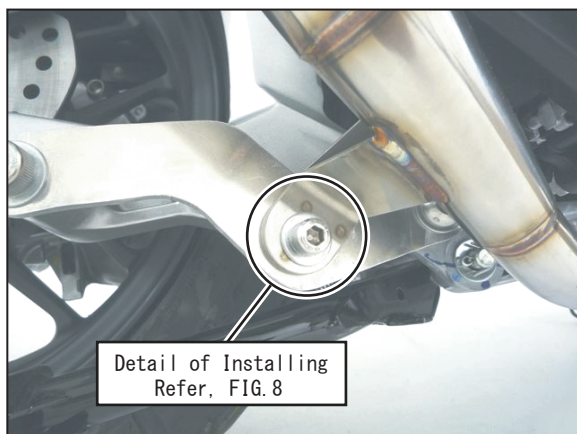

FIG. 7

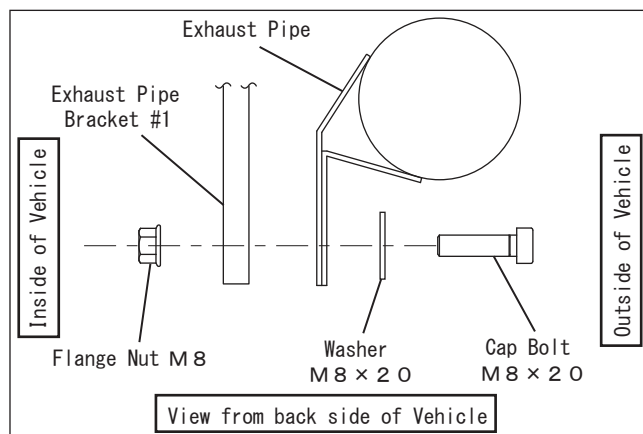

FIG. 8

- 8) Place Silencer Band Rubber inside Silencer Band, and slide them on Silencer Assy. Then, fix Silencer Band on Silencer Bracket with 2 of each Button Bolt M6x15, SUS Washer M6 and Flange Nut M6. (See Fig. 9). Tighten bolts by hand only at this stage.

CAUTION Be sure to place Silencer Band at right angles to Silencer Assy. If neglected, it may cause breakage to Silencer Band.

CAUTION Before hand-tighten Silencer Band, make sure silencer sleeve and Silencer Band fit evenly and there is no opening between them. If neglected, it may cause deformation of silencer sleeve.

REFERENCE Make sure not to tighten bolts completely in order to adjust the position of Silencer Band later.

REFERENCE Cut excess of Silencer Band Rubber with scissors etc. when placing it inside Silencer Band.

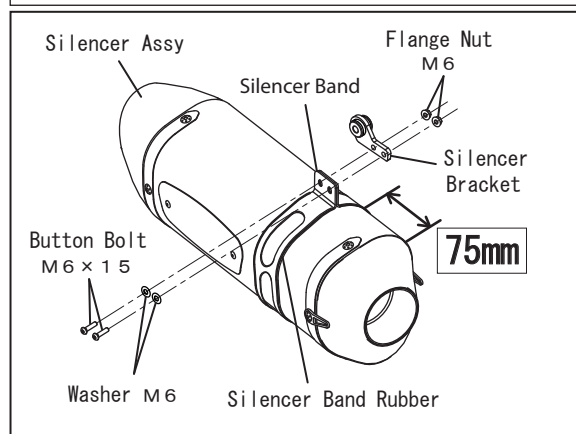
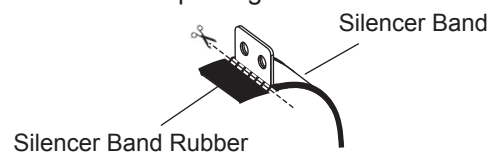

FIG. 9

- 9) Mount Silencer Assy on the Exhaust Pipe. Then, Install Exhaust Spring onto spring hook on Exhaust Pipe and Silencer Assy (See Fig. 10).

CAUTION Make sure that exhaust spring is hooked to spring installation toolmly. If neglected, it may cause injury

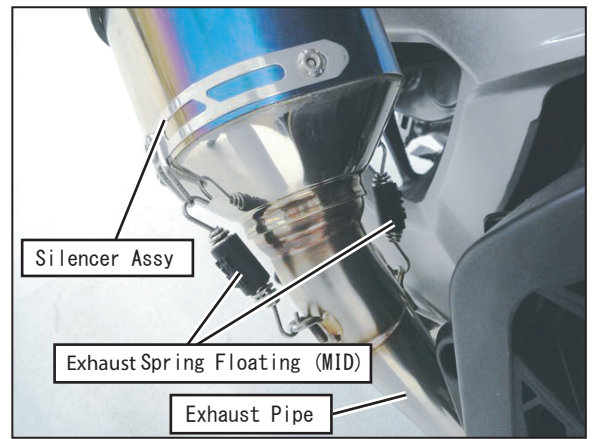

FIG. 10

- 10) Mount Silencer Bracket on Stock Silencer Bracket by Using Cap Bolt M10x55 P1.25 and Washer M10x26 Tighten bolt by hand only at this stage (See Fig. 11, 12).

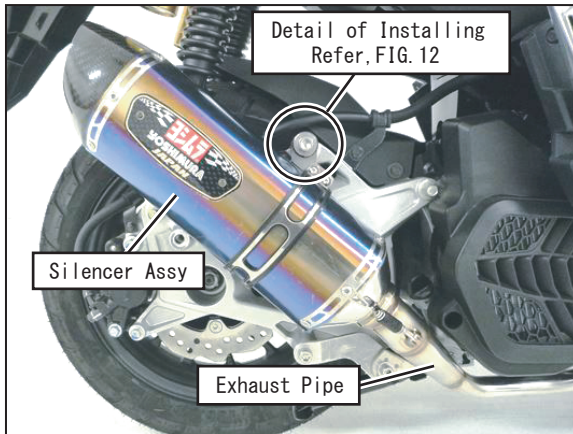

FIG. 11

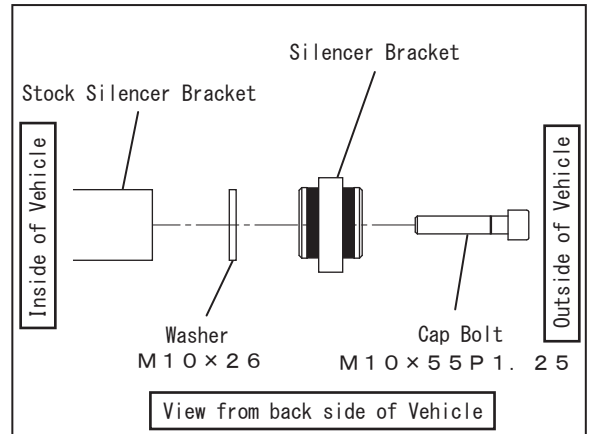

FIG. 12

- 11) Check from back and adjust angle of Silencer Assy and Keep proper clearance between Yoshimura exhaust system and Other components such as swing arm. Then, tight and torque 2-Stock Nuts of the Exhaust port, Cap Bolt M8 on Exhaust Pipe Bracket, 2-Button bolt M6 on Silencer Bracket and Then Cap bolt M10 on Silencer Bracket (See Fig.13).

Tightening Torque	2-Stock Nuts	: 15 Nm
	Cap Bolts M8	: 23 Nm
	2-Botton Bolts M6	: 10 Nm
	Cap Bolts M10	: 39 Nm



FIG. 13

- 12) Please check clearance between Silencer and Rear Suspension If clearance is less than 10 mm. Please remove Washer M10x26 attach in step10 and using Spacer 10-24-5 instead.

CAUTION The safety distance is 10 mm or more

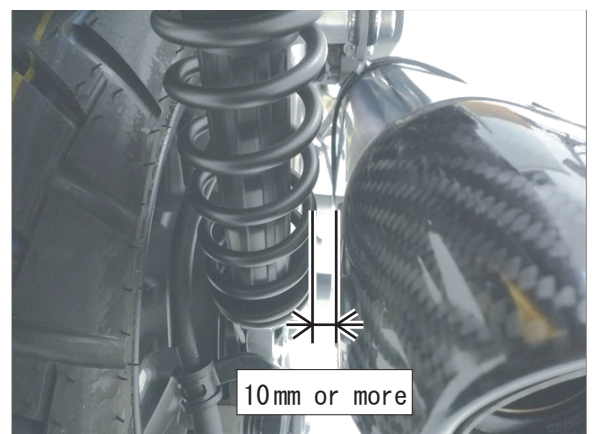

FIG. 14

- 13) Make sure to keep enough clearance between Yoshimura Exhaust System and other components such as wing arm or Silencer Bracket. In case there is no clearance, Please loosen bolts and readjust the position of the Exhaust Pipe and Silencer Assy .
- 14) It is recommended whole Exhaust System to be wiped down with dish soap to remove oil and fingerprints. This will prevent from tarnishing of finish after Exhaust System has heated up.

! CAUTION When cleaning silencer, use soft cloth and do not use metal polish or parts cleaner. If neglect, the paint of Emblem and Metal Magic finish may come off or Titanium Blue color may tarnish.

- 15) Warm-up engine, and inspect the exhaust leaking. If "after fire" sounds severely, seal the gaps of joint with silicone gasket etc. Then, tighten all bolts further after engine has cooled down. If any problem is found, please follow through instruction steps carefully again.

REFERENCE It is normal for new silencer to smoke until inside oil residue burns off.



HONDA ADV150 R-77S

REFERENCE

Yoshimura Asia recommends silencer inner wool repacking every 5,000km (3,000miles) in order to get Yoshimura exhaust performance fully. Climate, riding condition, and frequency of ride are direct contributing factors for inner wool worn out. Keeping high engine revolution also promotes further wool consumption. Weigh new silencer assy (or silencer assy after repacking) and record the weight in order to compare with weight after use. For silencer repacking, please contact local Yoshimura Asia distributor for further information.

- ⊙ Check each bolt sometimes to see that there is no failure condition such as poor tightening.
- ⊙ Quality control is implemented on all products. If, however, any defect or failure is found, please notify Yoshimura Asia through the selling dealer. Necessary technical service or replacing of the product will be made.
- ⊙ Due to improvement, the specifications and price of the product are subject to change without notice.
- ⊙ For any information regarding this product, please address inquiries to Yoshimura Asia Co., Ltd.

Yoshimura Asia Co., Ltd.
118/3 Moo 18, KLONGNUENG, KLONGLUANG, PATHUMTHANI 12120, THAILA
Web site: <http://www.yoshimura.asia>